

QICKLY® DOUBLE SHELVING UNIT CARCASS 3 FILE HEIGHTS

W/H/D: 70.1X110.5X42.6 CM

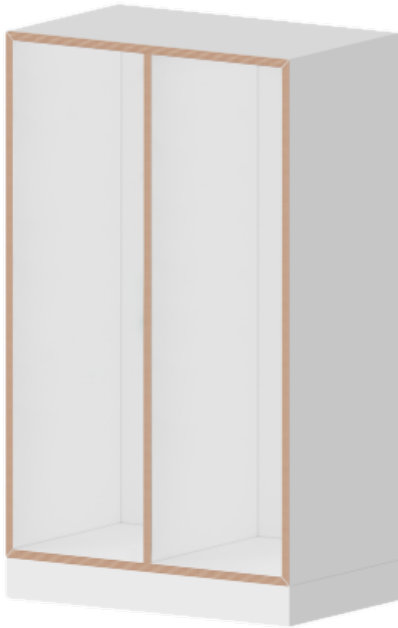

PRODUCT

Our qickly® cabinet and shelving system impresses with its 45 degree miter and ABS edge in multiplex look. The body color is white melamine. This ultra-modern design makes classrooms and offices a real eye-catcher.

qickly® shines in both schools and offices thanks to its ample storage space and mobility.

Start planning your individual cabinet and shelving system now or simply expand your existing system. One carcass - many options, whether shelves, doors, boxes or castors, qickly® leaves nothing to be desired

The material thickness of the walls and shelves is 19 mm, the fixed rear panel is 8 mm thick and guarantees a high level of stability.

As the name of our product range suggests, the qickly® cabinet and shelving system impresses with its fast delivery. The carcass is delivered to you disassembled including assembly instructions for self-assembly.

qickly® - Smart. Fast. Simple.

FEATURES

- 45 degree miter
- ABS edge in multiplex look
- intelligent modular system
- White melamine decor
- stable 8 mm thick back panel
- qickly® - delivered quickly

Accessories

Free-standing

Mobile

Item number	SLS23	
Width / Height / Depth	701 mm / 1105 mm / 426 mm	27.6" / 43.5" / 16.8"
Placement	Platform stand, Mobile	
Mounts application field	Primary school, Secondary school, Office furniture	
Material	Melamine board	
Product line	Quickly	
Packages	Package dimensions WxHxD	Package weight
SLS23-1	1156 x 109 x 463 mm / 45.5 x 4.3 x 18.2"	25 kg / 55.1 lbs
SLS23-2	751 x 67 x 461 mm / 29.6 x 2.6 x 18.1"	12 kg / 26.5 lbs
Total weight	37 kg / 81.6 lbs	

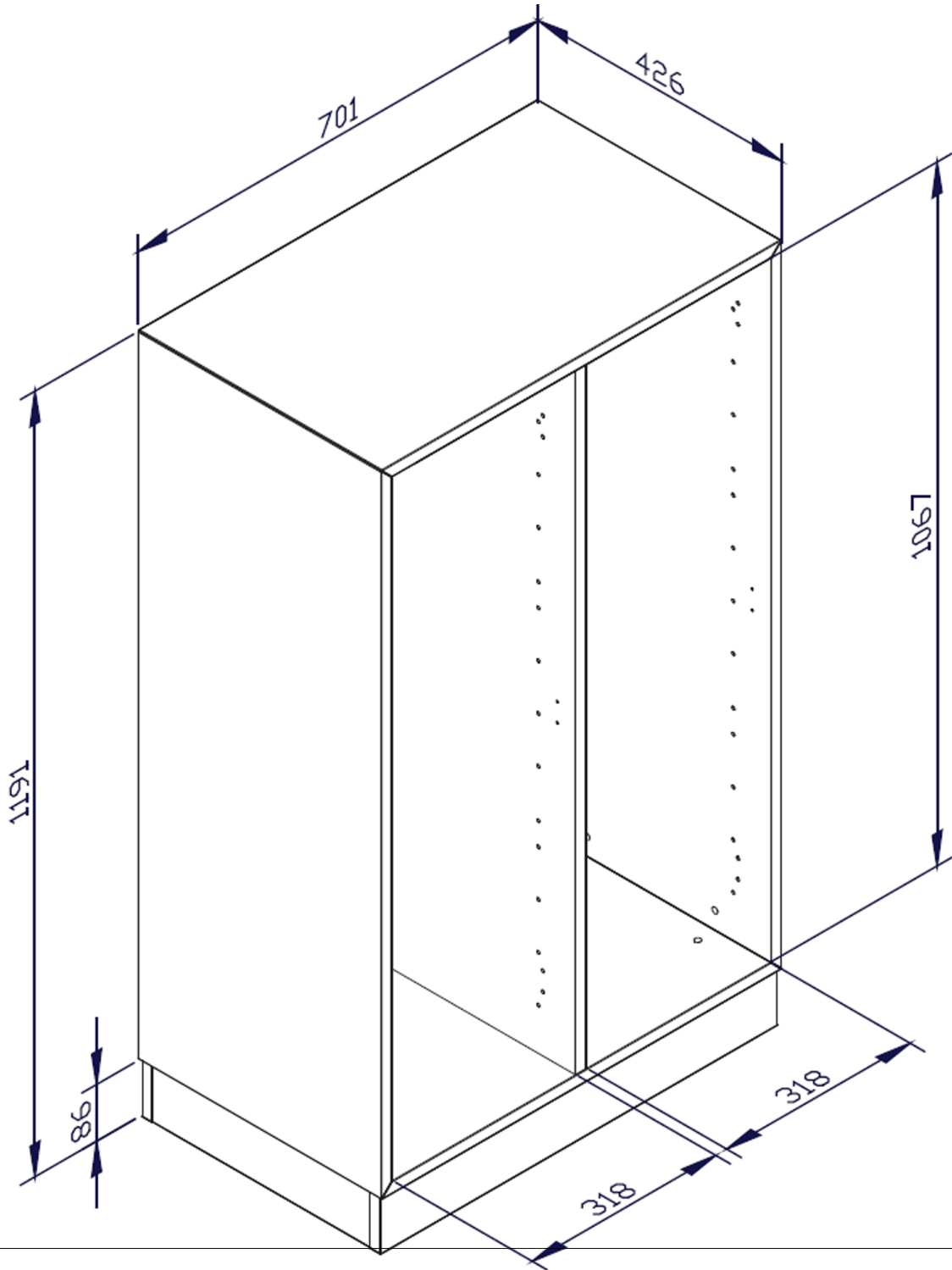

Conen Produkte GmbH
 Conenstr. 4
 54497 Morbach-Gonzerath
 Germany

T +49 6533 75-100
 F +49 6533 75-600
 E info@conen-produkte.de
www.conen-produkte.de

© Copyright by Conen Produkte GmbH